

Influent is fed into the top of the clarifier (A) and flows under a baffle to the integral flash mixing tank (B). The flash mixing tank is where flocculant may be added with a PolyMark™ polymer blending system and blended with the fluid using an optional high speed mixer.

From the flash mix tank, the fluid flows over a baffle into the integral flocculation tank (C), which may include an optional low speed mixer.

From the flocculation tank, the fluid flows downward through the feed channel between the two plate stacks to the sludge chamber at the bottom of the clarifier. At this point, the fluid velocity decreases and large particles drop out of suspension.

The flow then enters the bottom of the plate stacks and flows between the settling plates. Between each of the plates, the fluid has a low velocity, laminar flow profile which encourages the remaining solids to settle on the surface of the lower plate and flow downward to the sludge holding tank.

As the solids are settling along the plate surfaces, the fluid is moving upward through the plate stacks, over the weirs, and into the discharge trough.

Clarified effluent is then discharged through a flanged pipe connection at the bottom of the trough. Sludge is periodically drawn off the bottom of the sludge holding tank at the bottom of the clarifier.

Sample ports are provided to assist with determining the sludge level, which is periodically pumped to a batch storage tank for further liquid-solid separation via an M.W. Watermark™ Filter Press for eventual disposal.

Fig.1a – Top View

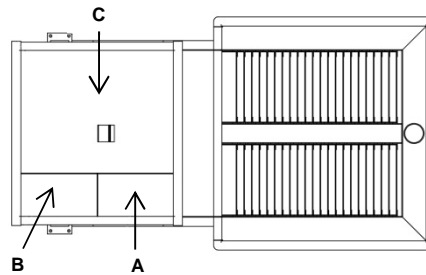

Fig.1b – Isometric View

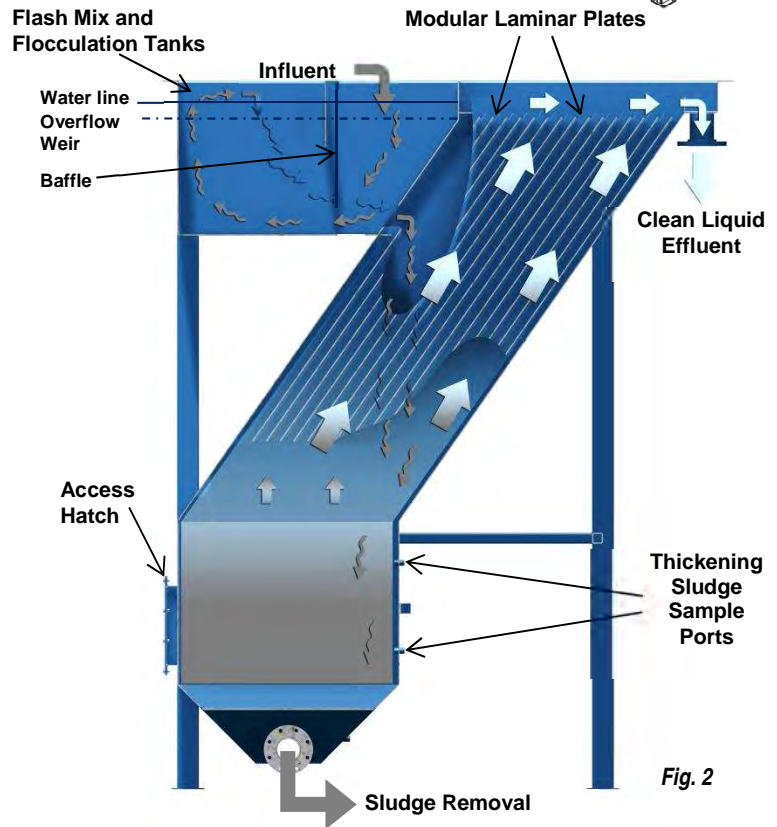
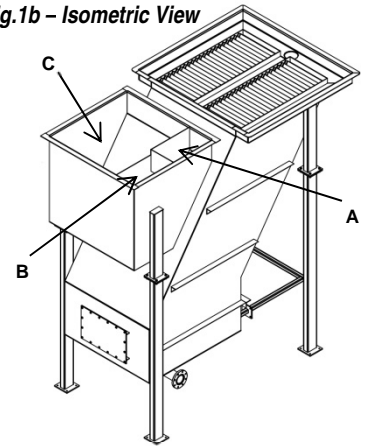
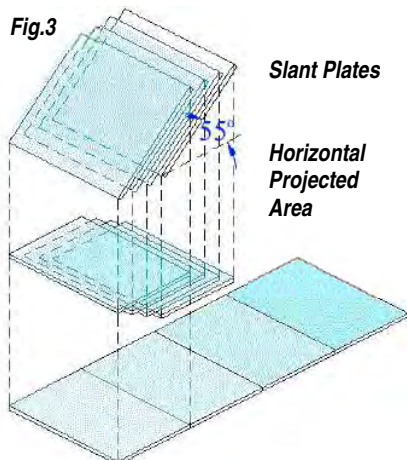

Fig. 2

Floor Space Requirement Horizontal vs. Slant Plate Clarifier

Fig.3



Equipment Design

M.W. Watermark™ Slant Plate Clarifiers are designed to provide efficient solids removal from a wide range of waste and process liquids. The settling plates are inclined at an angle of 55° with 2-inch spacing. The slope of the plates allows the solids to settle by gravity while the fluid moves upward through the plate stack.

Stacking the plates reduces the floor space required by the clarifier compared to a horizontal clarifier. The inclined plate design allows the total gravity settling area to be as much as ten times the floor space occupied by the clarifier.

Fig. 3 illustrates the floor space reduction resulting from stacked plates.